

Notch



TRI
MO
QBISS

DESIGN BY

pininfarina



TRIMMO QBISS

Notch

DESIGN BY

pininfarina

Content

PININFARINA/TRIMO_0BISS

CONTENT

04

04

**Sharing
for innovation**

06

**Design
Drivers**

08

**Design
Approach**

16

**Notch Wall
System**

34

**From exterior
to interior**

40

**Materials, Colors
and Finishings**

Legacy High Quality Attention To Details

Pininfarina is a design house of international repute, a symbol of Italian style in the world. With almost 100 years of experience, it is a flexible partner able to offer competitive products and services based on the values of the brand: purity, elegance and innovation.

From cars to buildings, from yachtes to lifestyle products, the work of Pininfarina is about the way we live and move.

With over 60 years of experience, Trimo is a seasoned expert in the field of creating highly efficient, sustainable, and attractive architectural wall and roof systems. Trimo believes in high-performance, simple, safe, and tailor-made building envelope solutions that meet its client's most varied needs. The company's commitment to excellence is evident in its approach to designing unique architecture and tailoring details.

pininfarina

**TRI
MO**

PININFARINA/TRIMO_QBISS

COLLABORATION INTRODUCTION

09



Brand Heritage

PININFARINA

Italian design powerhouse founded in 1930, boasts a rich heritage shaping automotive elegance. With a commitment to innovation and timeless aesthetics.

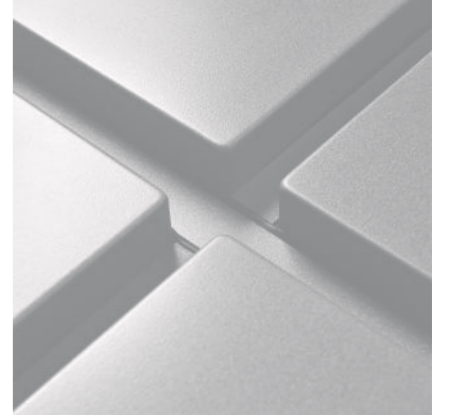

Technological breakthrough

TRIMO

Qbiss product developed by Trimo is a world-class-engineered, prefabricated architectural metal wall system with built-in benefits that offers a true alternative to conventional built-up systems. Qbiss stands for quality building innovative smart skin.

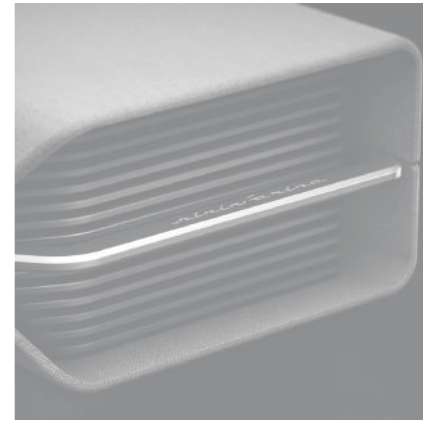

Tech and innovation

IN DESIGN AND MANUFACTURING

In product design, innovation technology ensures efficiency, precision, and novel solutions. From advanced prototyping to smart materials, technology elevates design, enhancing functionality and user experiences.

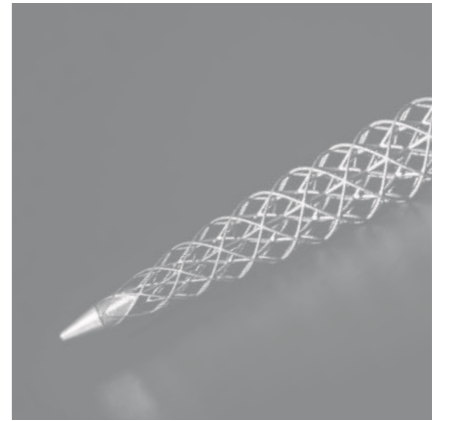

Luxury and Arts

THE PRODUCT AS A PIECE OF ART

Art in design enriches aesthetics, evokes emotions, and enhances creativity. It fosters uniqueness, transcends trends, and communicates narratives, resulting in compelling, memorable, and impactful experiences.

From Local to Global

The transition from local to global represents a process in which ideas, aspirations, and initiatives that originate at the local level gain scope and influence on a global scale.

Notch the visual landscape



Notch All in one strategy



1. Qbiss panels

Long vertical panels in a set of different sizes

2. Curves

Engraved Curves

3. Plugins

Decorative and lightening plugins

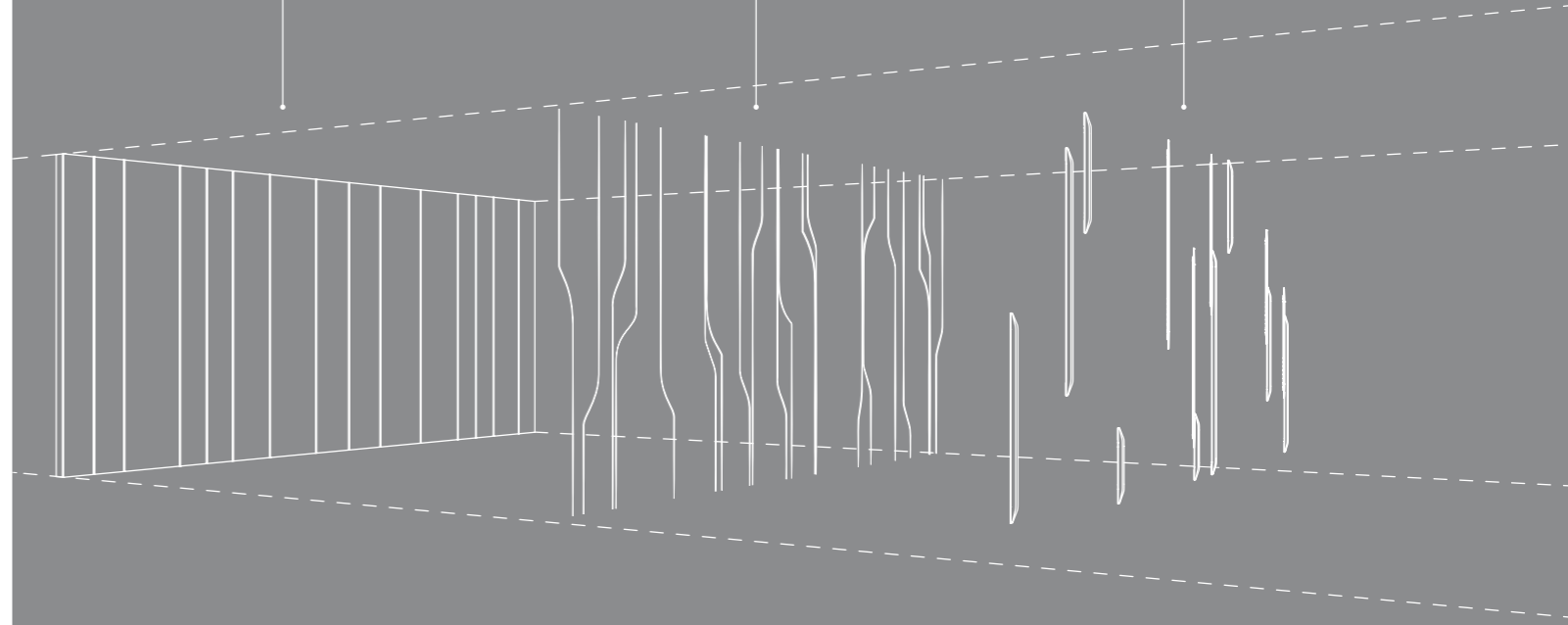



Notch Wall System

18

Qbiss panels
Engraved Curves
Plugins

Notch Wall System

The new design system developed by Pininfarina Architecture for Trimo's Qbiss product. It customizes Qbiss panels with 3 fundamental components: different vertical panels cuts that can be mixed together, a graphic alphabet of curves and glyphs, and a "wing" modular plugin for decoration and illumination which highlights the vertical thrust.

Notch Wall System

Qbiss panels sizes and types

For exterior and interior applications

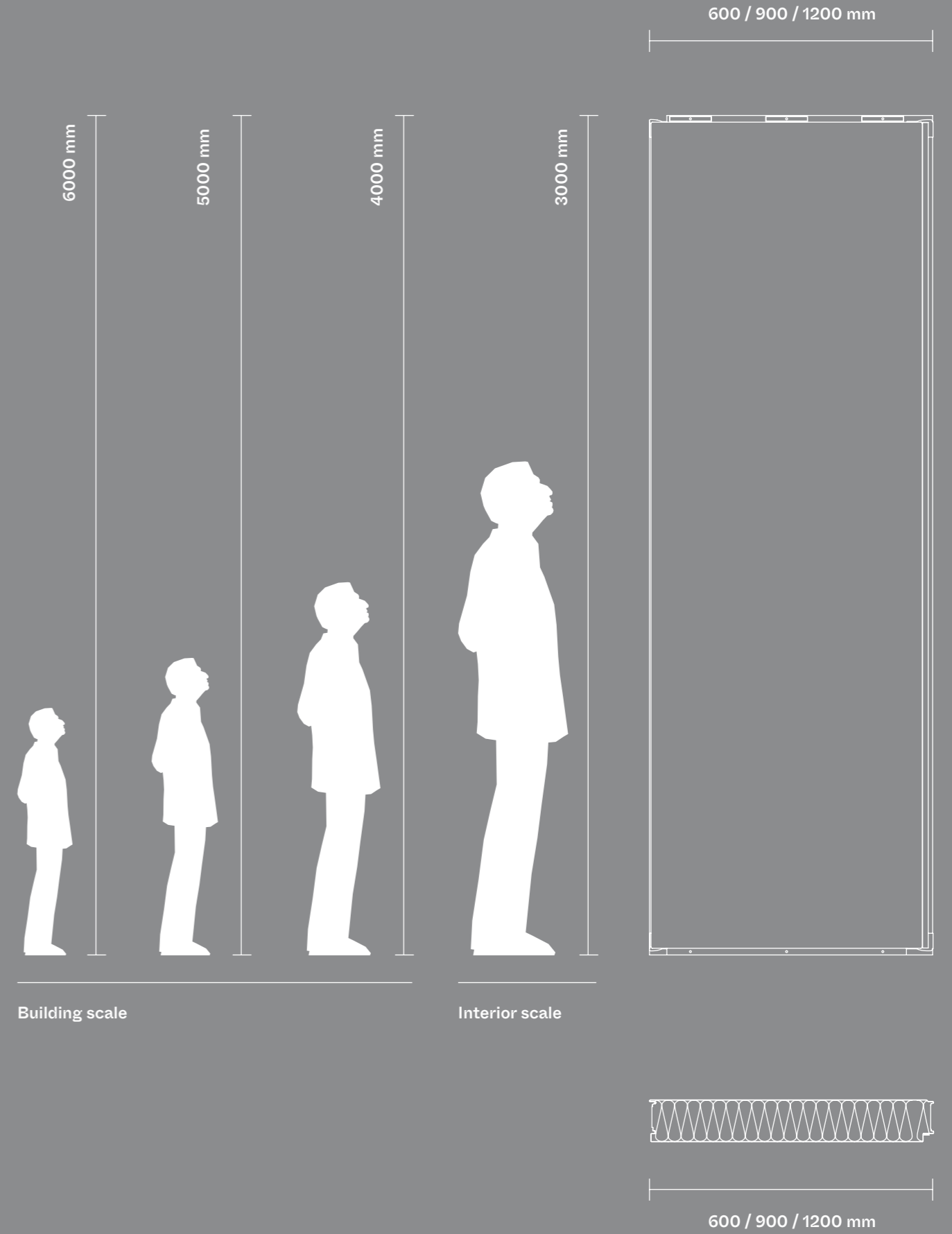

Notch Wall System Engraved Curves

The embossment depth is dynamic and follows the technological capabilities of engraving in various depths from 0 to 2 mm.

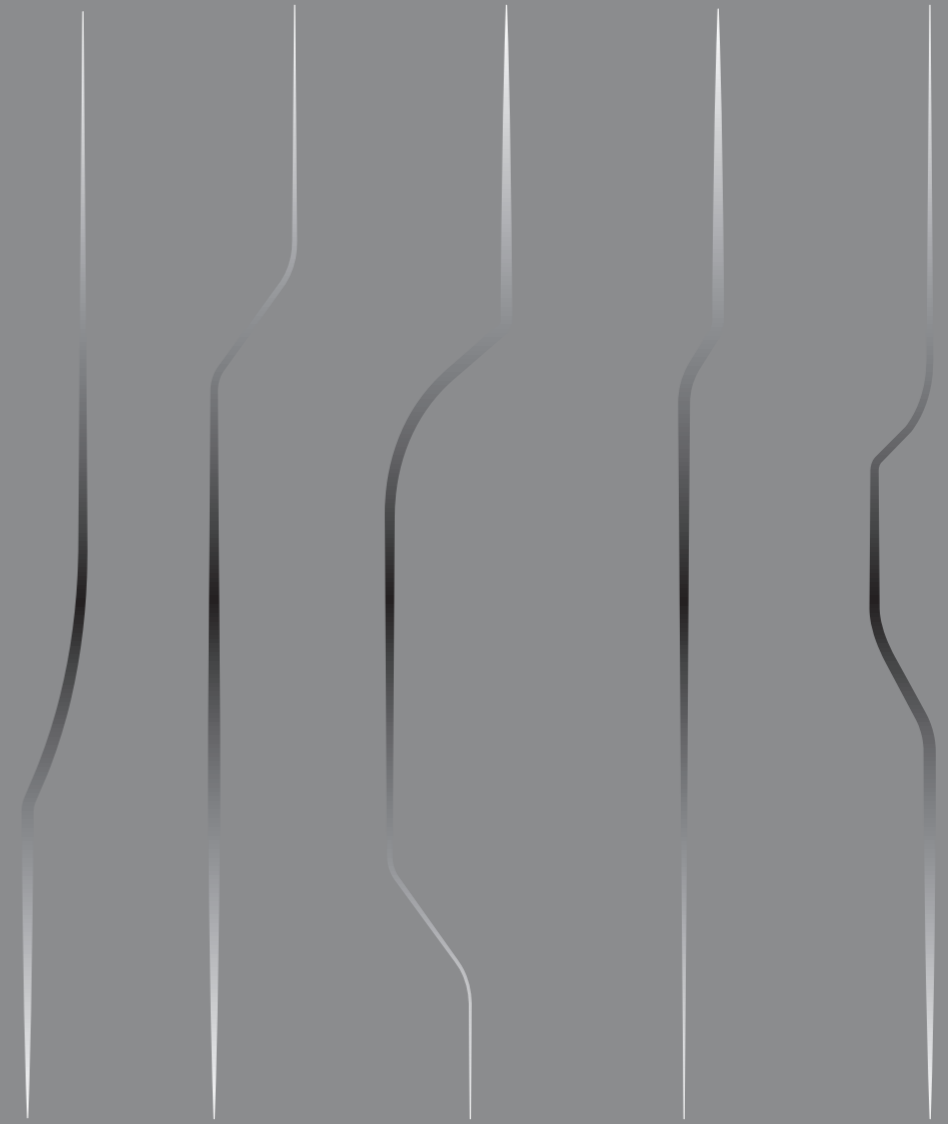

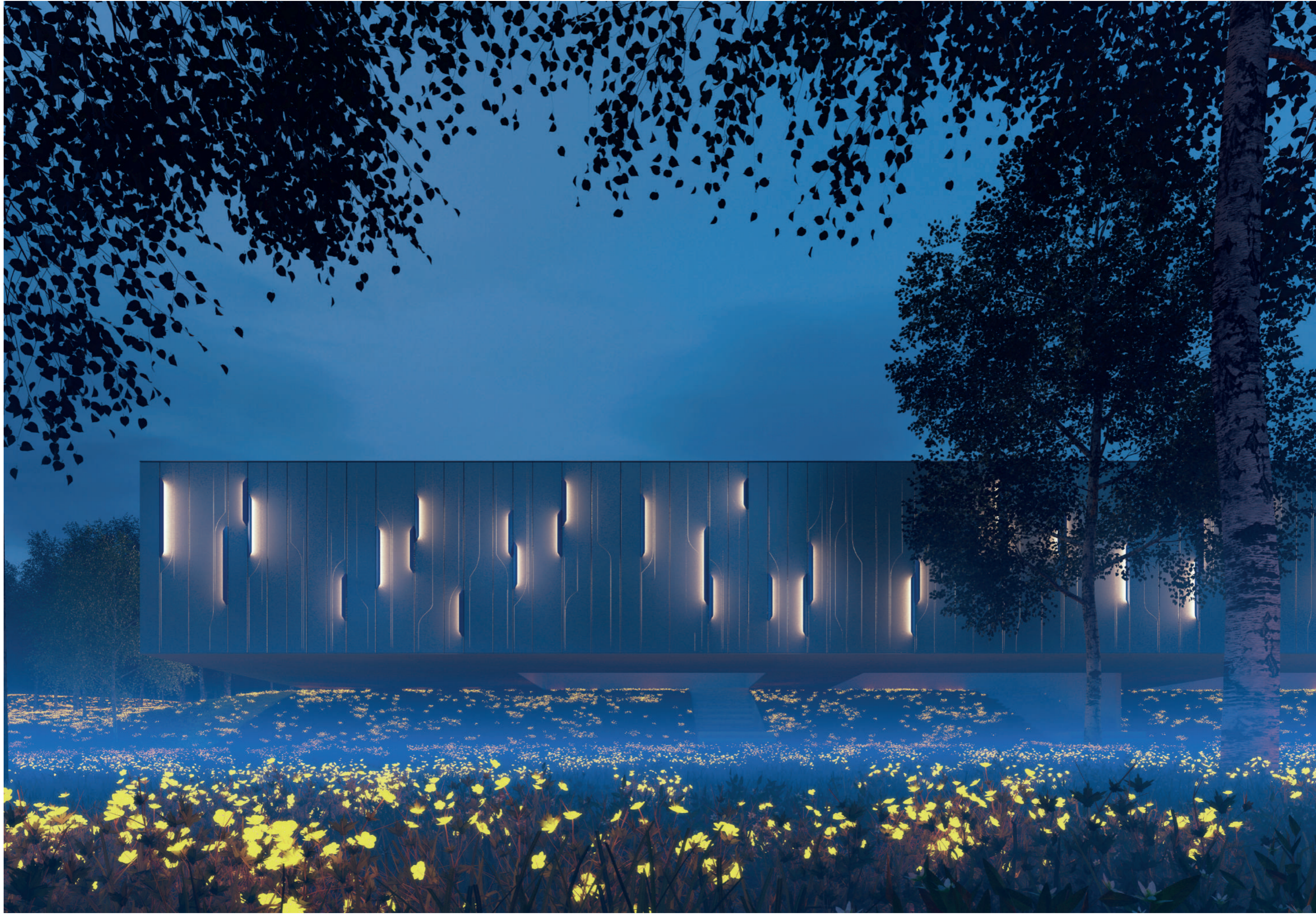

Notch Wall System Plugins

Wings are also represented in two proportional scales and two sizes within each scale. They are designed and equipped to accommodate different profiles and different materials.

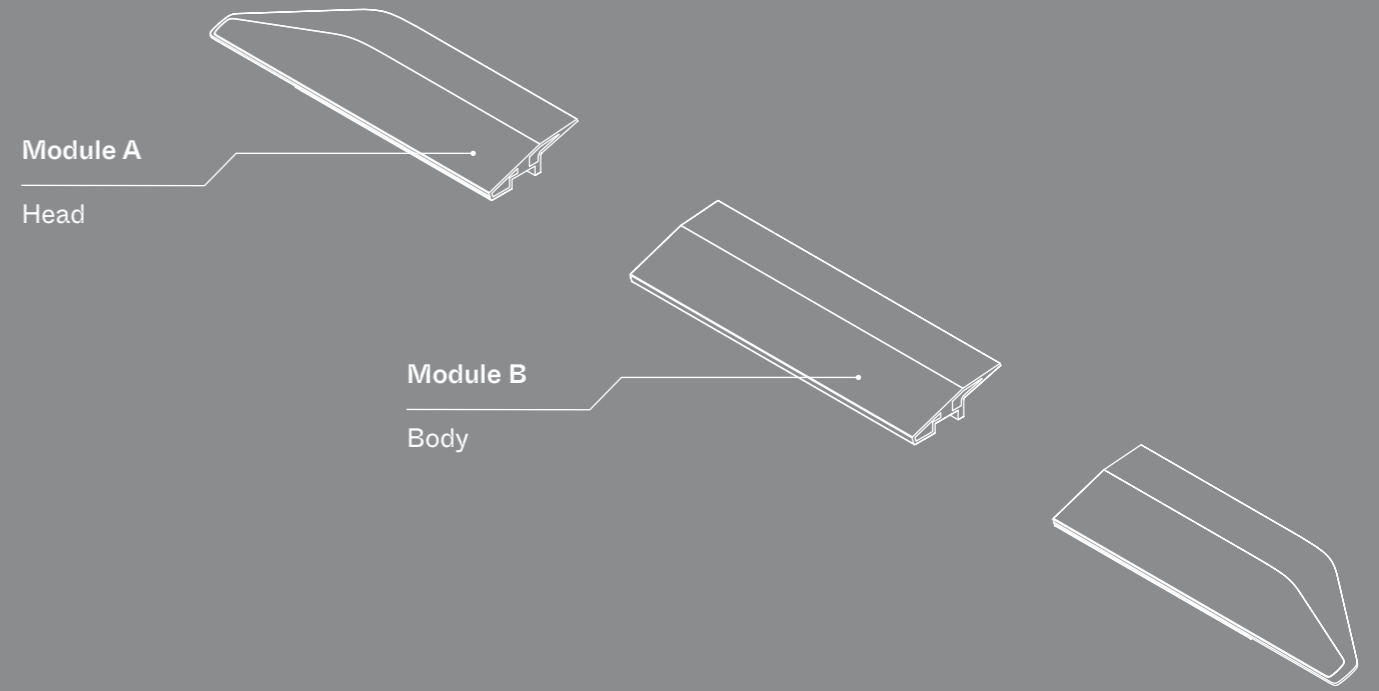

Exterior

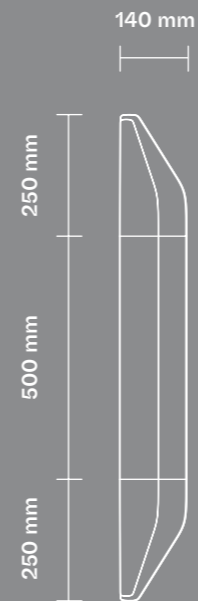

Interior

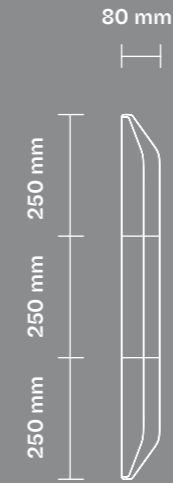
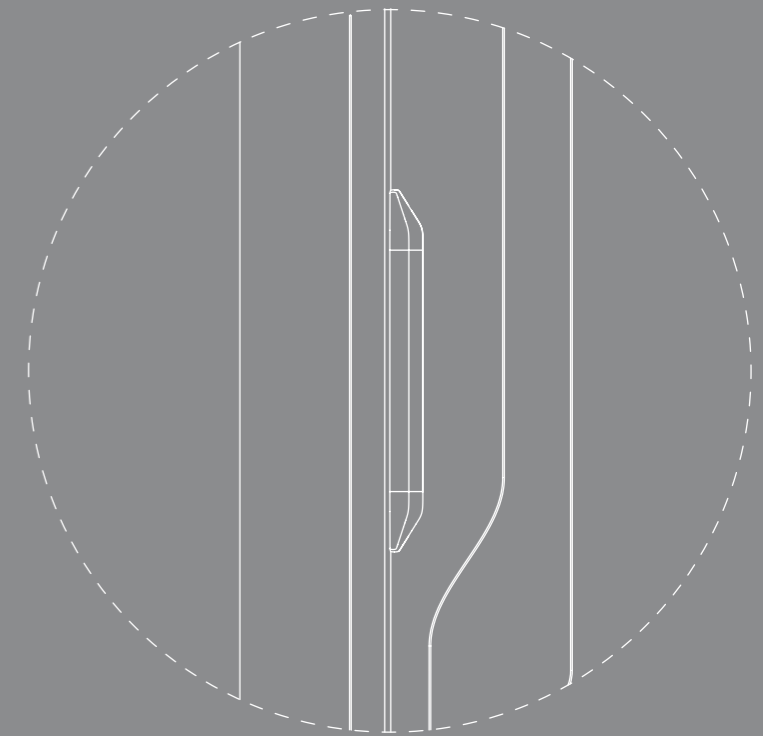
Installation along
the vertical gaps

Closed wings

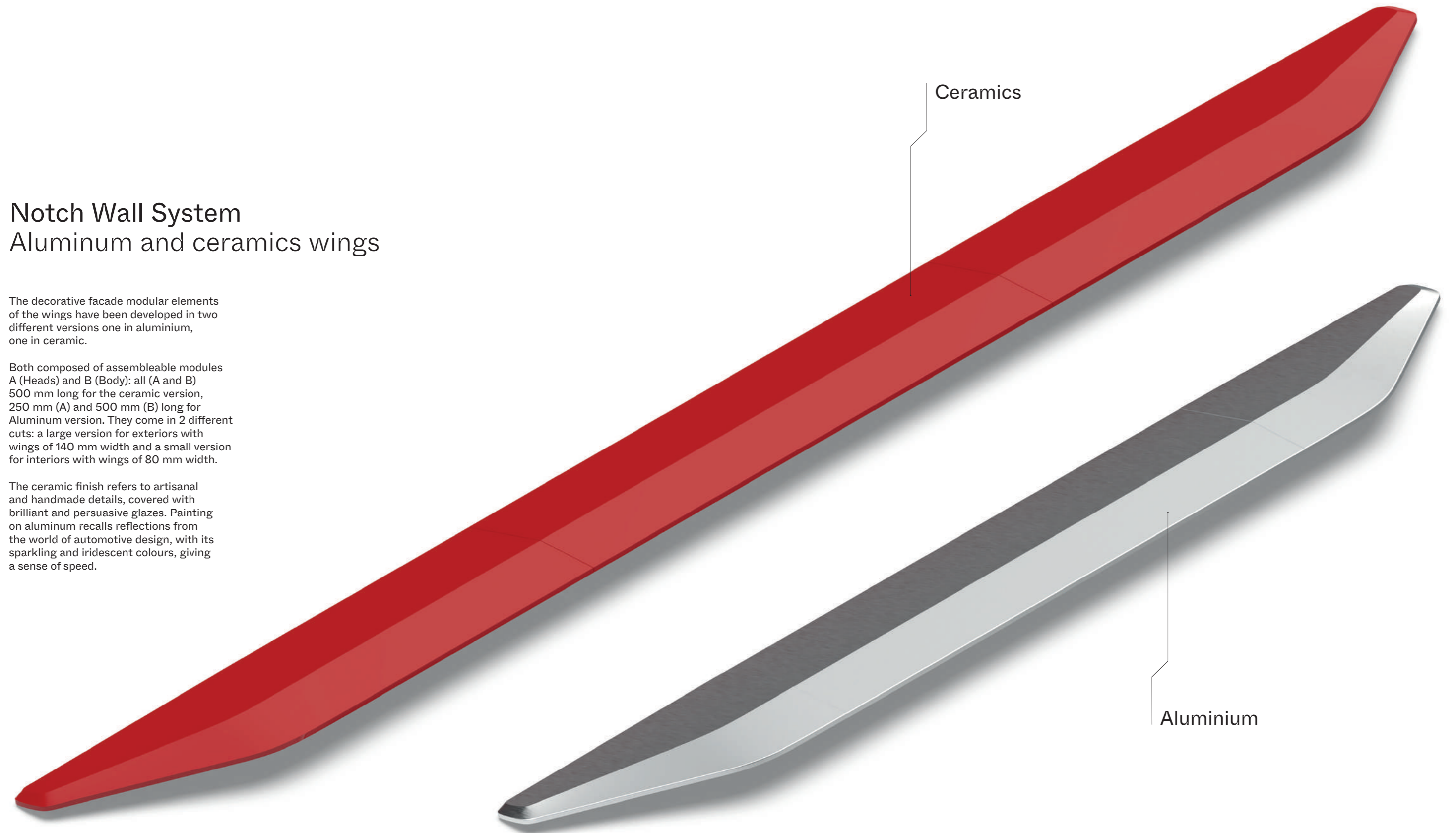

Notch Wall System Aluminum and ceramics wings

The decorative facade modular elements of the wings have been developed in two different versions one in aluminium, one in ceramic.

Both composed of assembleable modules A (Heads) and B (Body): all (A and B) 500 mm long for the ceramic version, 250 mm (A) and 500 mm (B) long for Aluminum version. They come in 2 different cuts: a large version for exteriors with wings of 140 mm width and a small version for interiors with wings of 80 mm width.

The ceramic finish refers to artisanal and handmade details, covered with brilliant and persuasive glazes. Painting on aluminum recalls reflections from the world of automotive design, with its sparkling and iridescent colours, giving a sense of speed.

Notch Wall System The Aluminum wing

The main difference between the second is that in addition to the different material, in the ceramic version the modules A and B of the heads and body all have the same length (modules of 500 mm for exterior or 250 mm for interior version), whereas in the aluminum version they have 2 different lengths (exterior version: modules of 250 mm for the heads and 500 mm for the body, interior version: 125 mm for the heads, body modules start with 250 mm length but can be extended according to needs). Both share the same track, but the ceramic version requires a separate aluminum attachment to the tile.

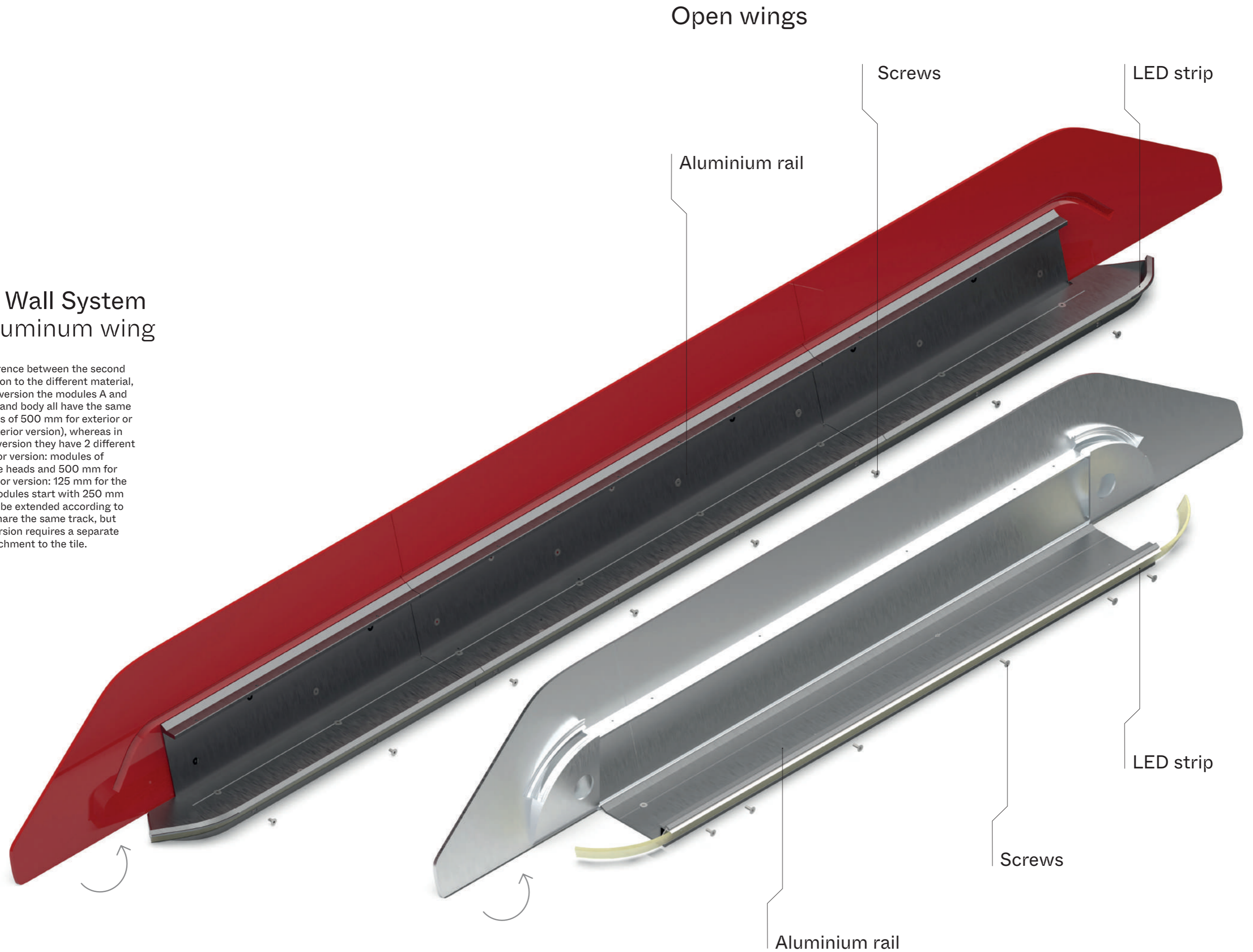



Local to global

The concept involves two scales, translating the transition of sizes from local to global, from large to small, from exterior to interior.

Notch Wall System

From exterior to interior

38

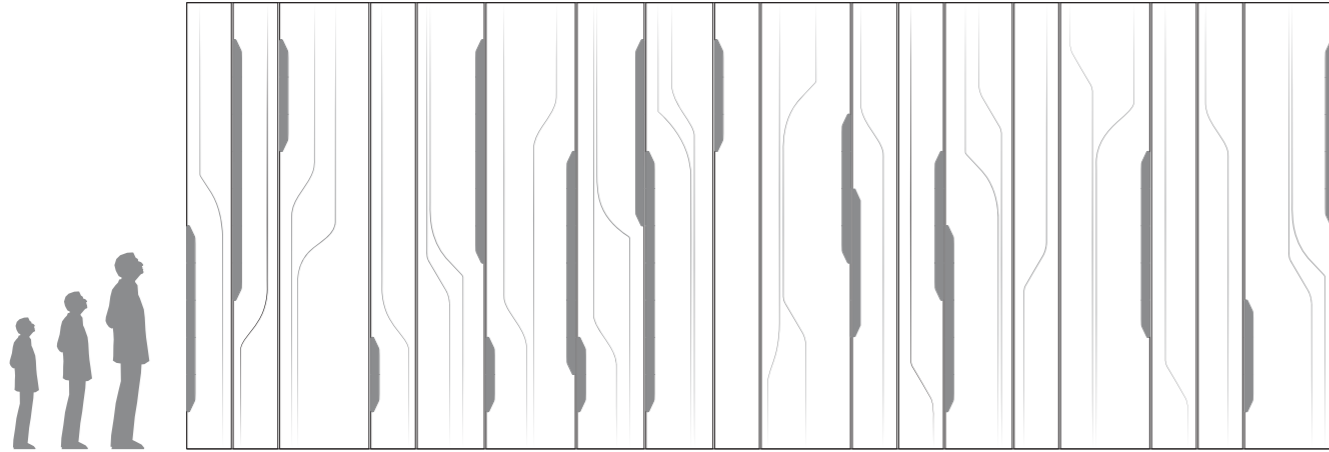

6m height / 5m height / 4m height

EXTERIOR SCALE



3m height

INTERIOR SCALE

*changement
of items dimensions

39



Ceramics

Ceramics redefine modern architectural facades by combining aesthetic versatility with functional durability. Architects exploit the material's diverse colors, textures, and finishes, creating distinctive designs. Ceramic cladding provides thermal insulation and low maintenance, contributing to sustainable structures.

Advancements in technology enable lightweight panels, streamlining installation and enhancing architects' creative freedom.

Aluminium

Aluminum is favored in facade design for its durable, lightweight, and versatile properties. Its corrosion resistance ensures longevity, while malleability allows intricate detailing.

Light weight facilitates easy installation, and thermal conductivity supports energy efficiency. Adaptable to various finishes, aluminum is a cornerstone in contemporary facade engineering, seamlessly combining aesthetics and functionality.

Colorcoat Prisma

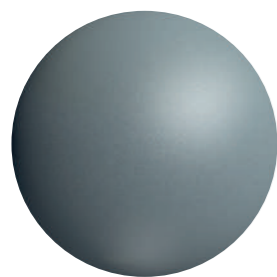

Sirius Sparkle



Orion Sparkle



Zeus Sparkle



Seren White



Seren Silver

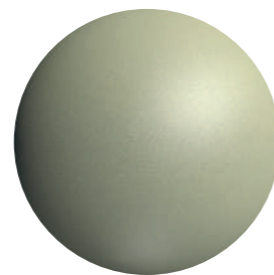

Seren Gold

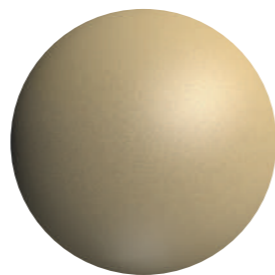

Seren Midas

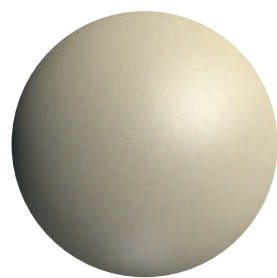

Seren Titan

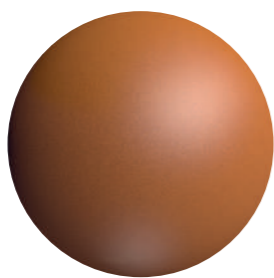

Seren Copper



Anthracite Solet



Seren Black

Special Metallic



Silver



Light Silver

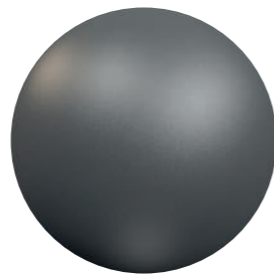

Dark Silver



Light Graphite

Solid Colors

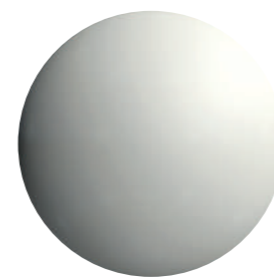

White

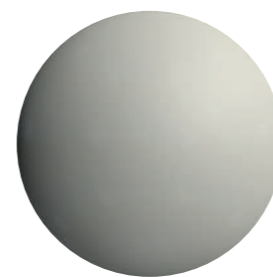

Gray White

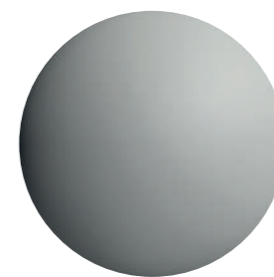

Light Grey

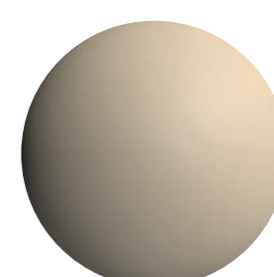

Cream



Sapphire Blue



Traffic Red

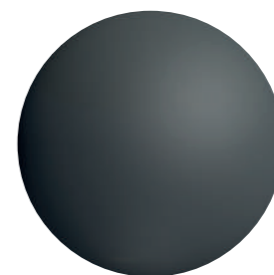

Basalt Grey

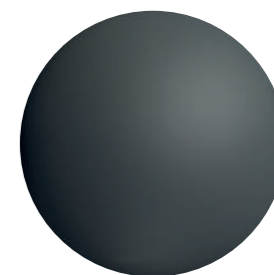

Anthracite

Materials, Colors and Finishing

Suggested combinations

Smooth

GRACE and SERENITY

Muted bronze gracefully glides, evoking a serene ballet of tranquility. Its smooth embrace whispers calmness, a gentle hue that soothes the soul with a velvet touch of relaxation.

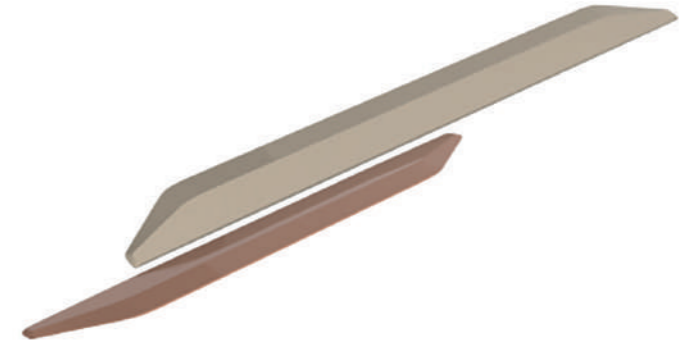

Performance

PININFARINA HERITAGE

Electric blue pulses through the air, igniting a euphoric dance of passion. The vibrant hue enchants, embodying a symphony of energy and exhilaration in every movement.

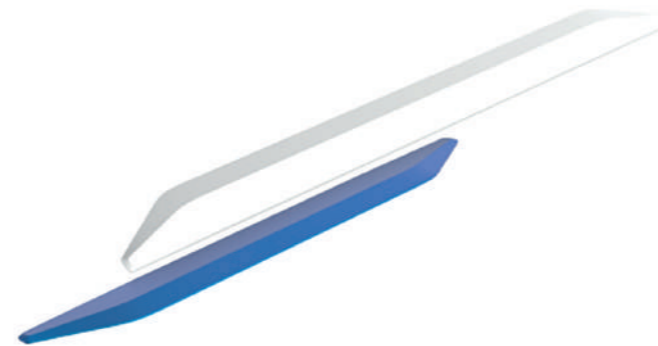

Plush

THE PRODUCT AS A PIECE OF ART

Rich gold envelops like a plush velvet hug, wrapping the senses in luxurious warmth. Its opulence whispers comfort, creating an inviting cocoon that beckons relaxation and indulgence.



Performance colors

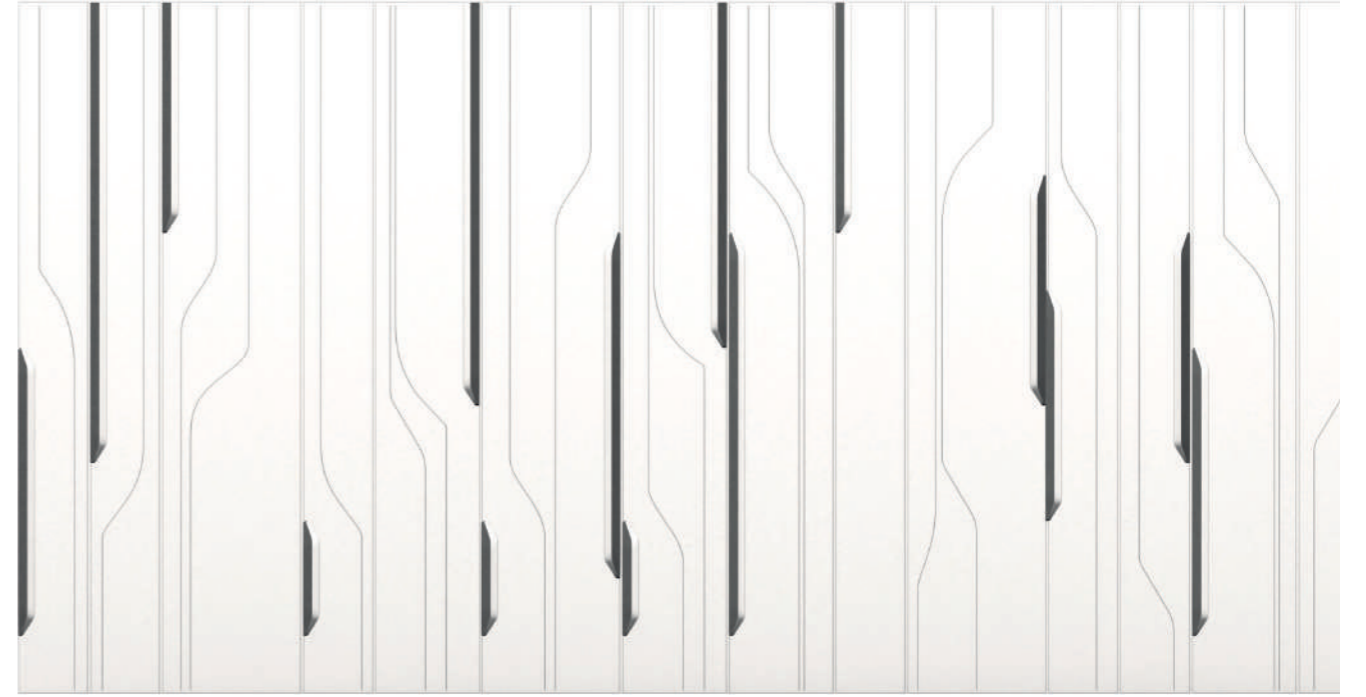

QBISS PANELS: Seren White
 WINGS: Dark Silver RAL 9007 or Seren Black

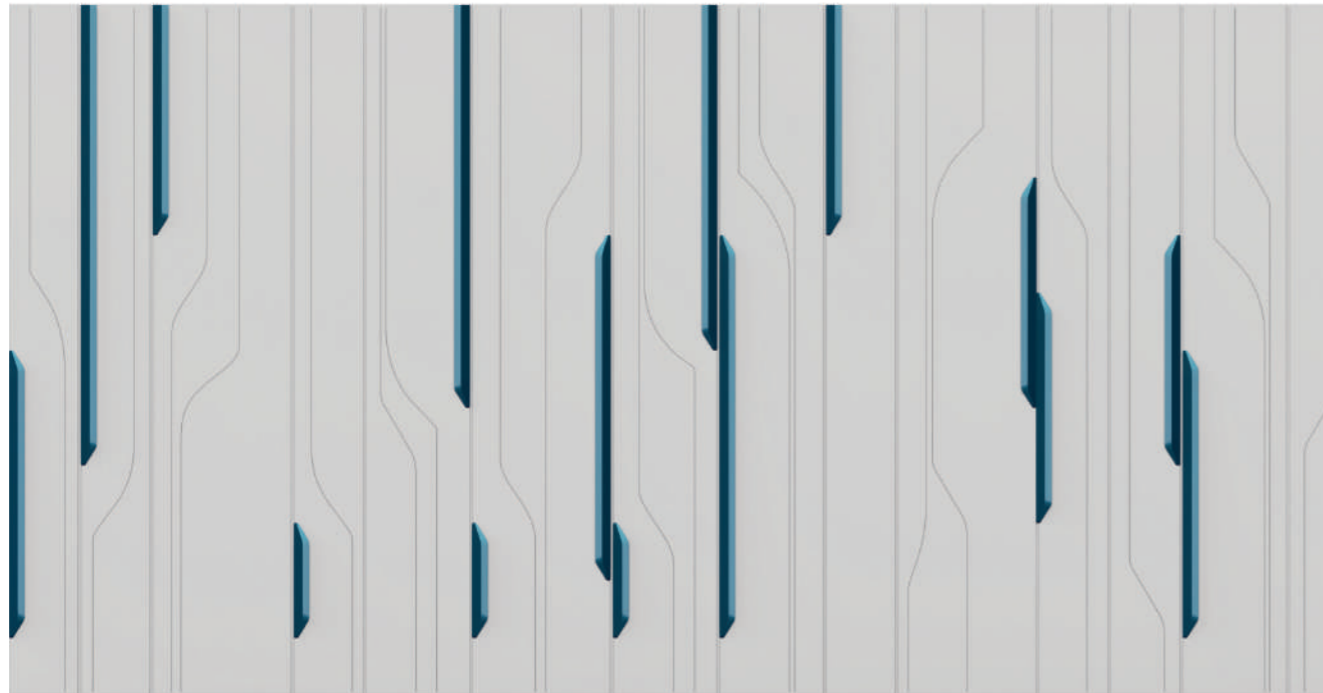

QBISS PANELS: Silver RAL 9006
 WINGS: Sapphire Blue RAL 5003

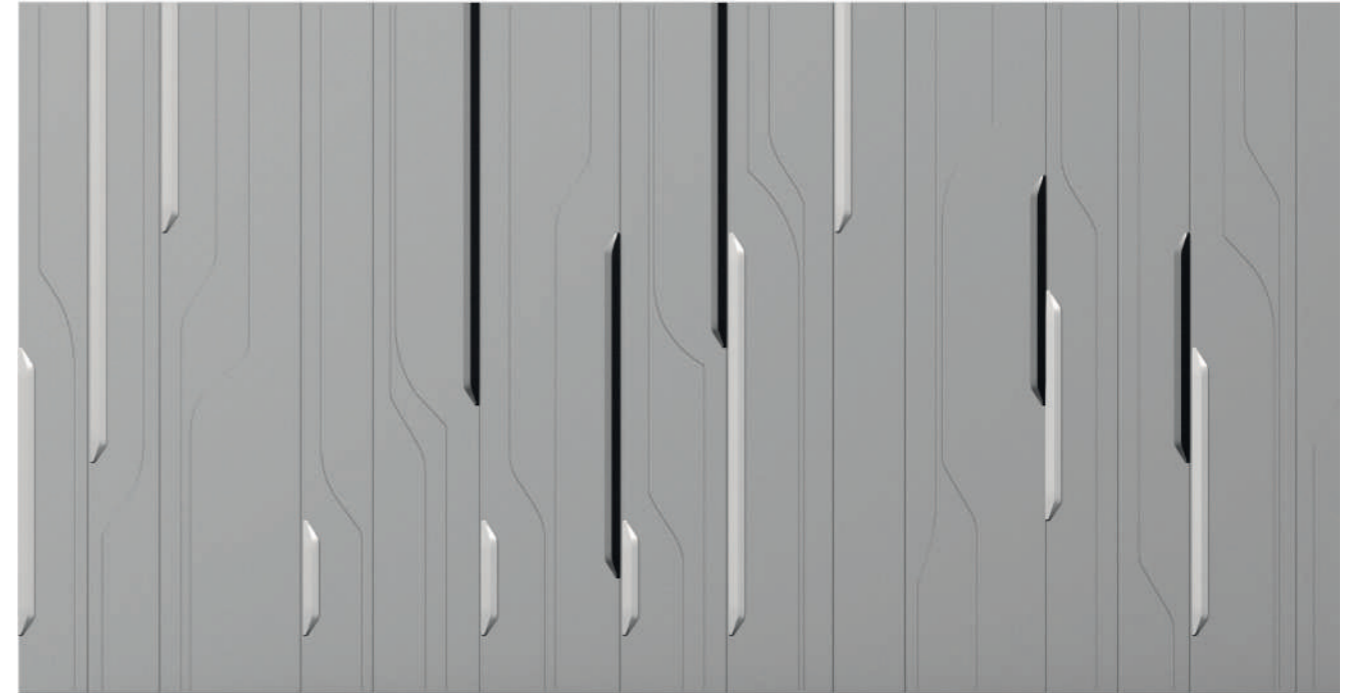

QBISS PANELS: Dark Silver RAL 9007
 WINGS: Seren Black and Seren White

Smooth colors

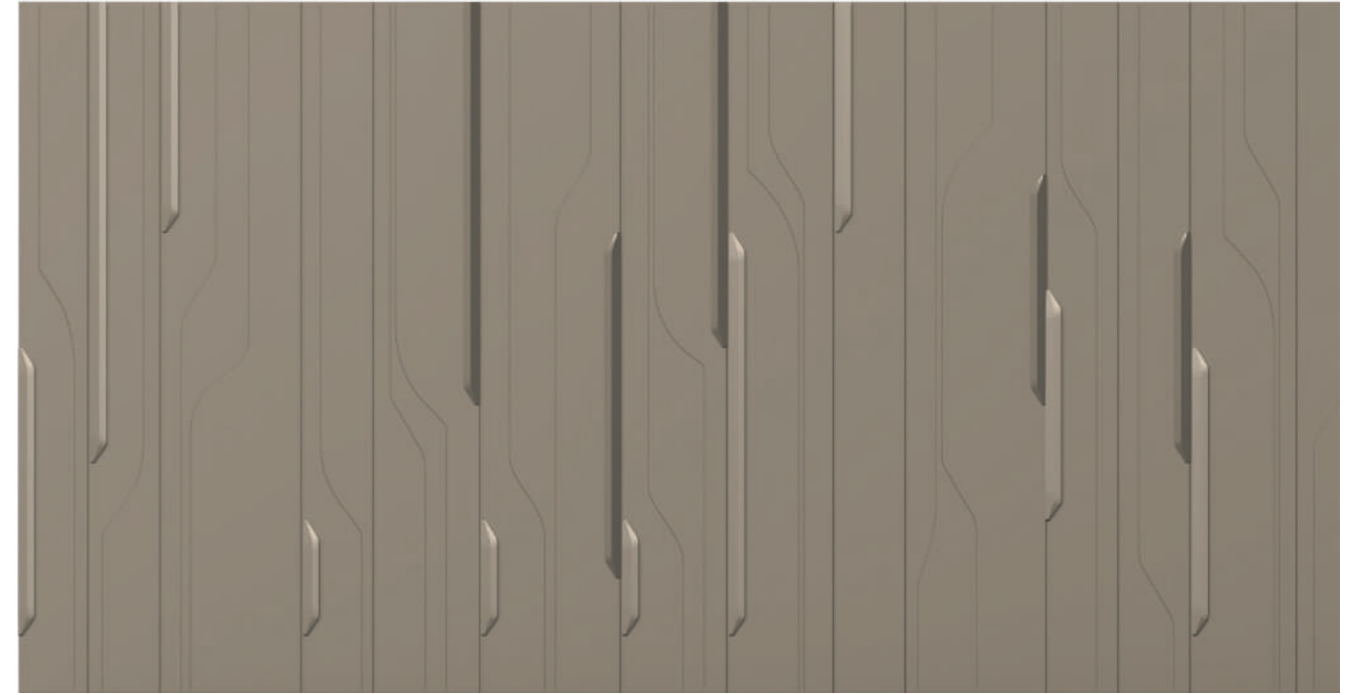

QBISS PANELS: Seren Titan
 WINGS: Seren Titan or Cream RAL 1015

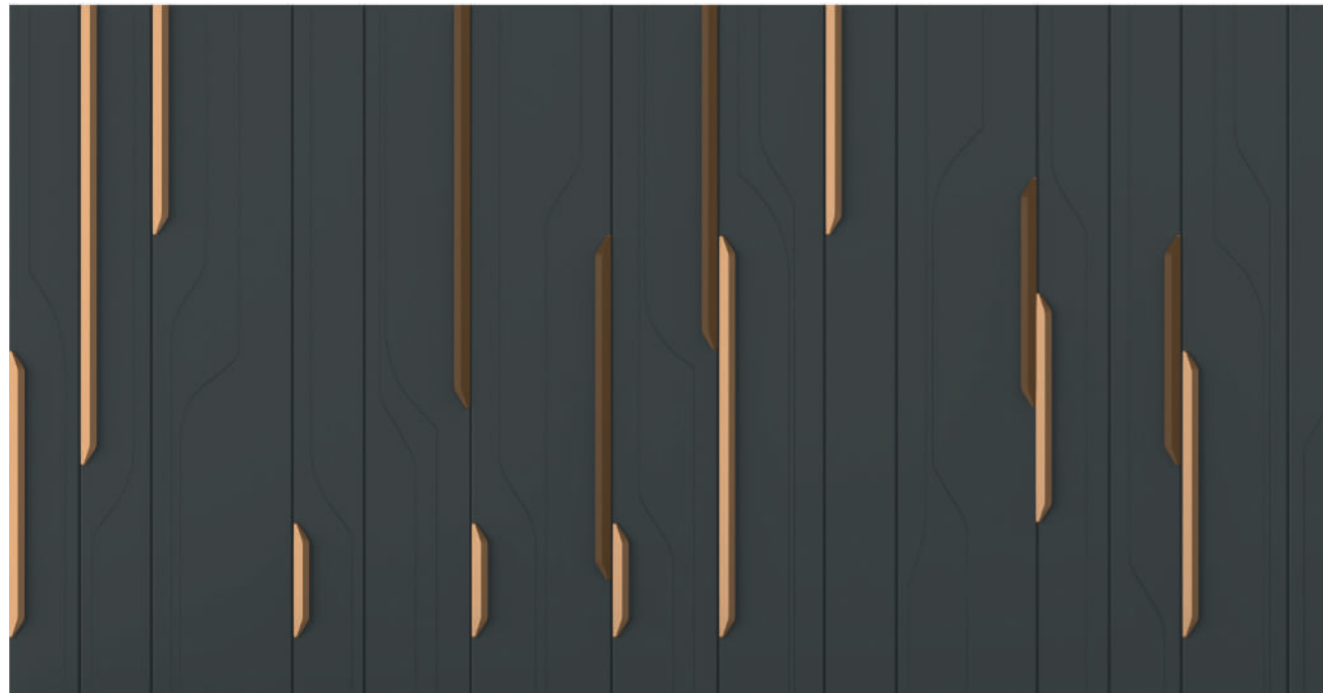

QBISS PANELS: Anthracite RAL 7016
 WINGS: Gold

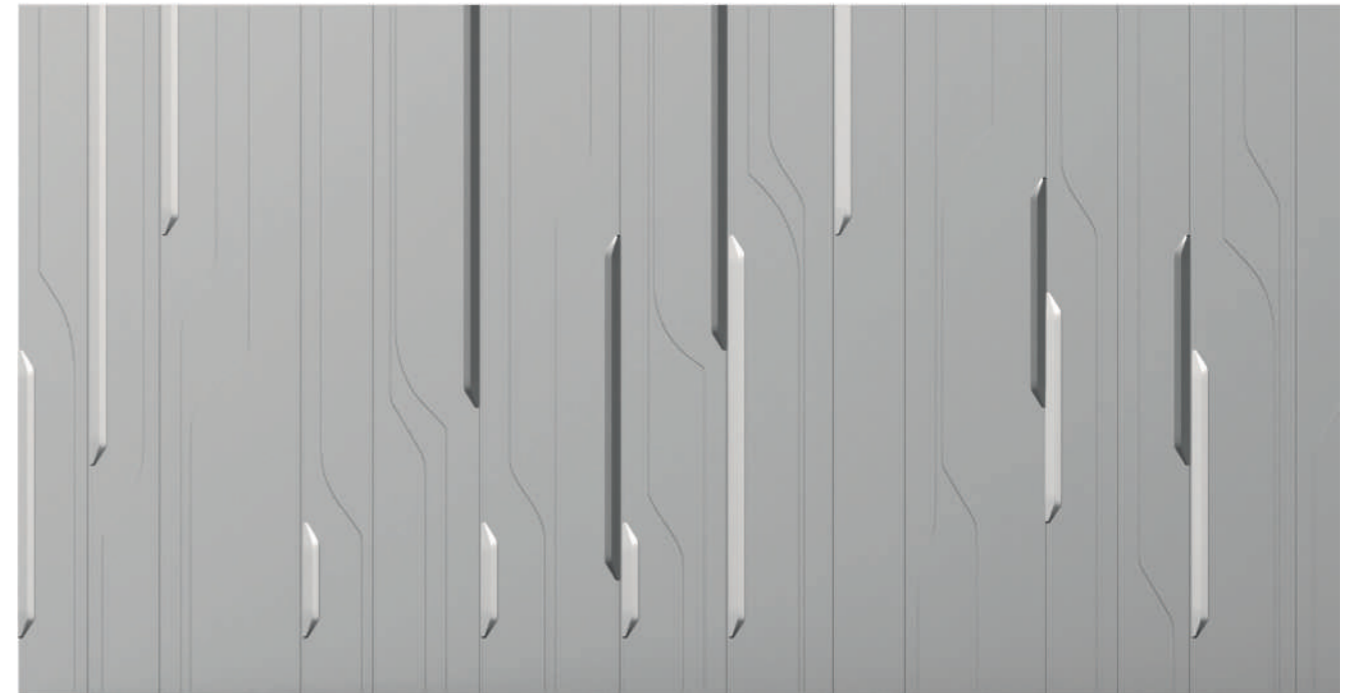

QBISS PANELS: Dark silver RAL 9007
 WINGS: Dark Silver RAL 9007 and Light Silver

Plush colors



QBISS PANELS: Zeus Sparkle
WINGS: Zeus Sparkle



QBISS PANELS: Seren Black
WINGS: Gold



QBISS PANELS: Seren White
WINGS: Traffic Red RAL 3020

Light
Dimmerable integrated
led lighting

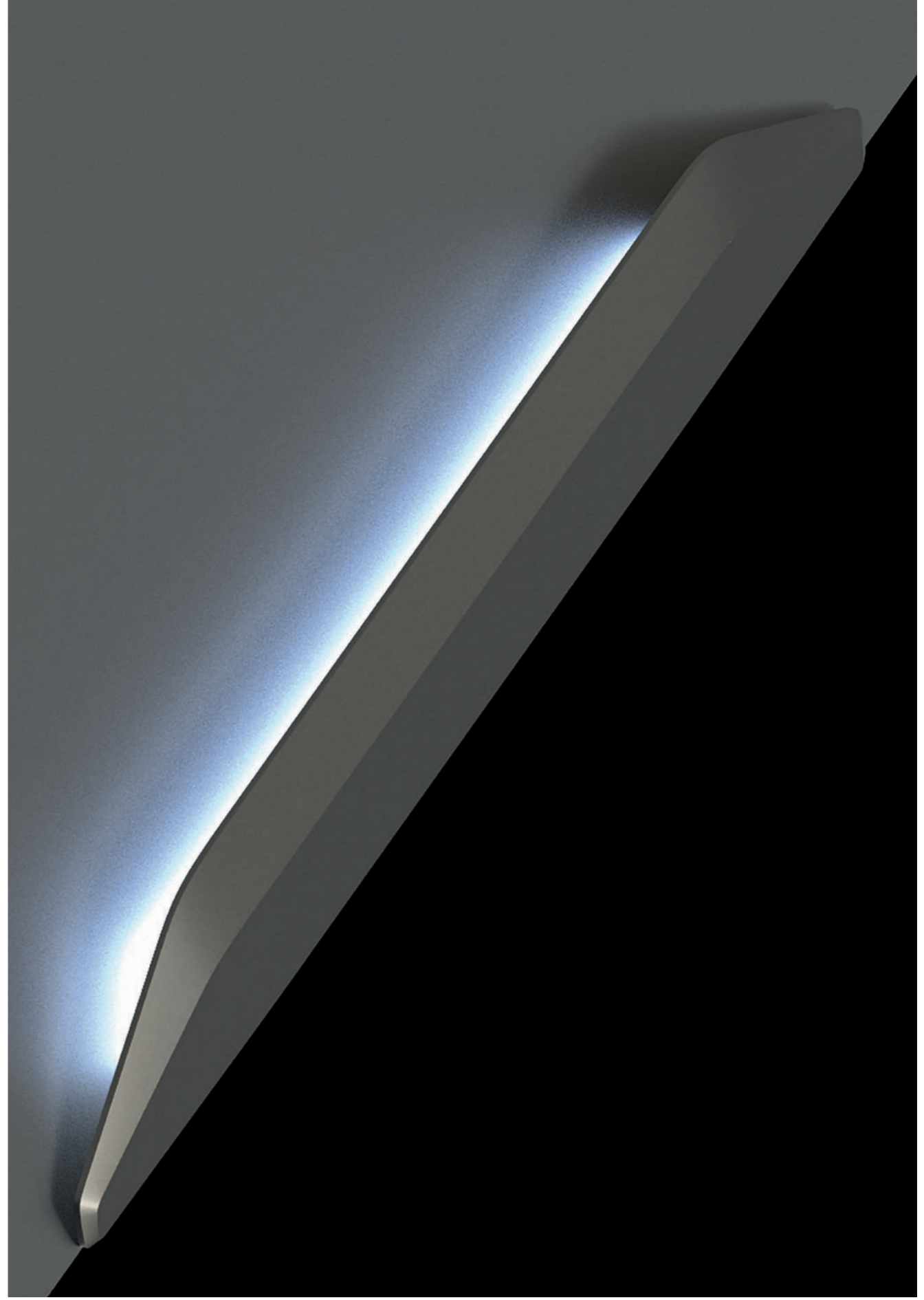

Light colors

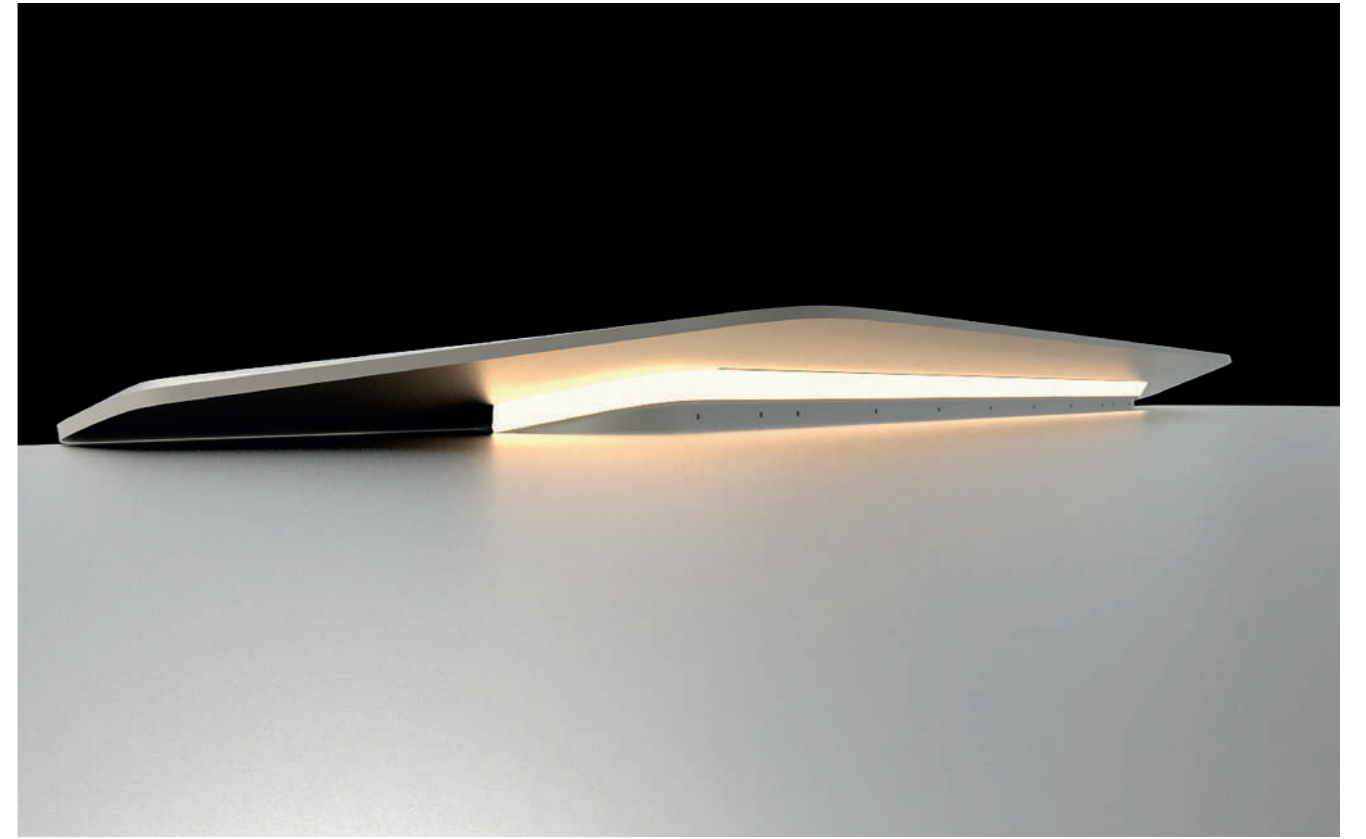

WARM WHITE

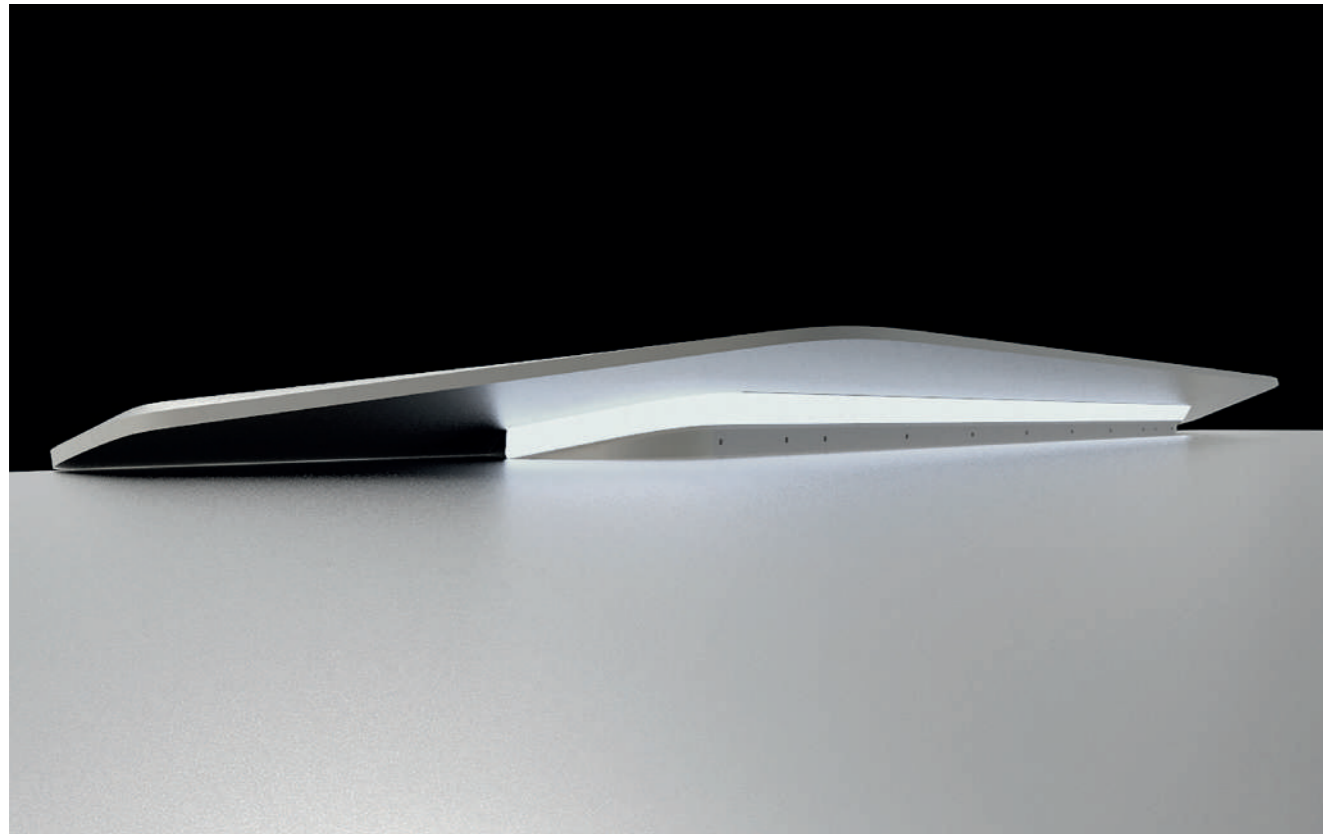

NEUTRAL WHITE

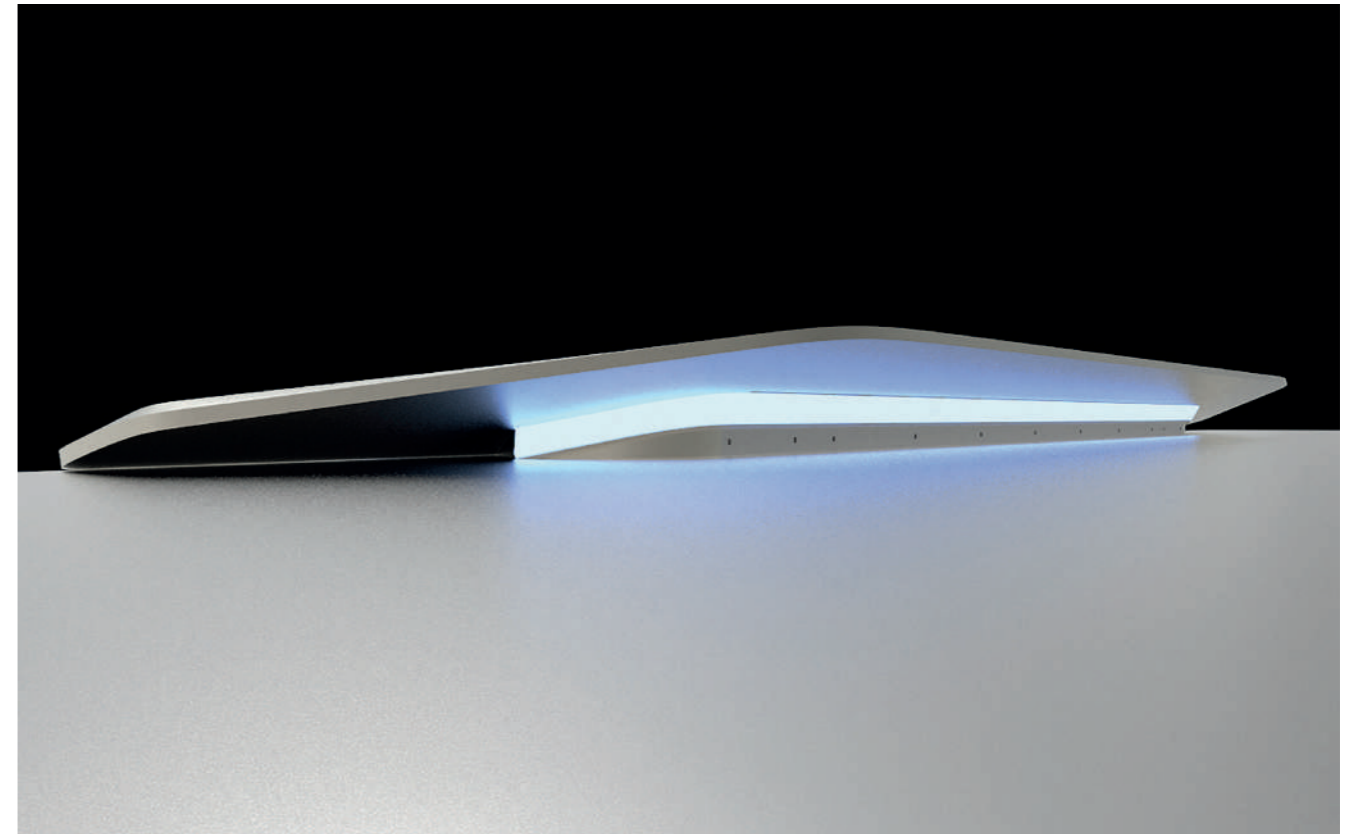

COLD WHITE

Notch Wall System

How to customize the engravings

Modify a glyph

The engraving and shape of the single glyph (see the "Glyph E" here in the example on the right) can be essentially modified through 4 geometric operations: mirroring, 180° rotation, vertical translation of the curved part and horizontal translation of the entire object on the panel.

These movements allow extreme flexibility and adaptability of the pattern to all needs and the creation of always unique and different beautiful compositions.

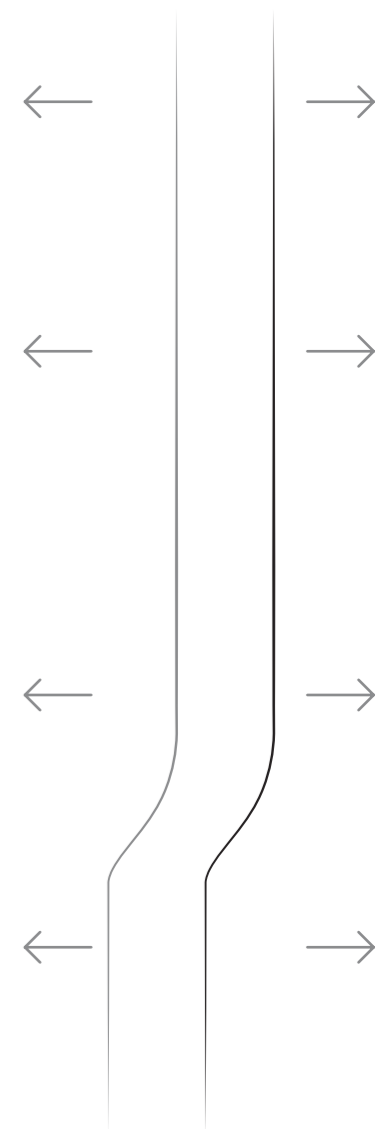
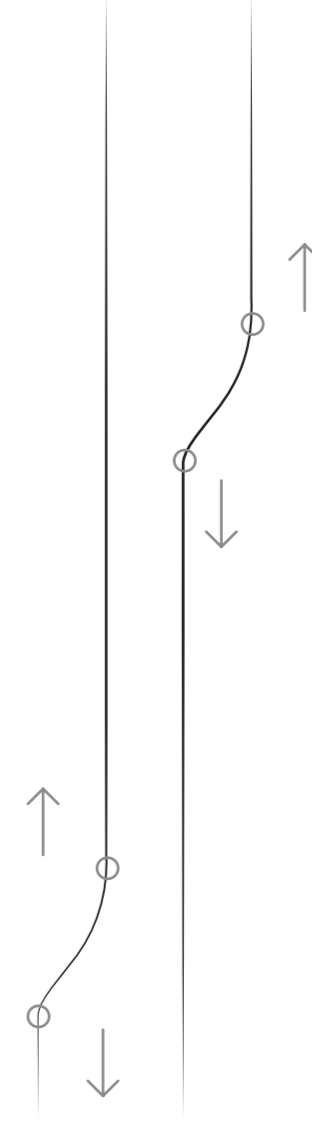

Mirroring

180° Rotation

Vertical translation

Horizontal translation
Multiple position possibility

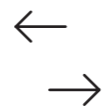

Mirroring

180 Rotation

Vertical translation

Horizontal translation

Notch Wall System

How to customize the engravings

Modify couples of glyphs

The engraving and shape of the couples of glyph (see the "Couple 9" here in the example on the right) can be essentially modified through 5 geometric operations: mirroring, shifting of the 2 curves, 180° rotation, vertical translation of the curved parts and horizontal translation of the entire object on the panel.

These movements allow extreme flexibility and adaptability of the pattern to all needs and the creation of always unique and different, beautiful compositions.

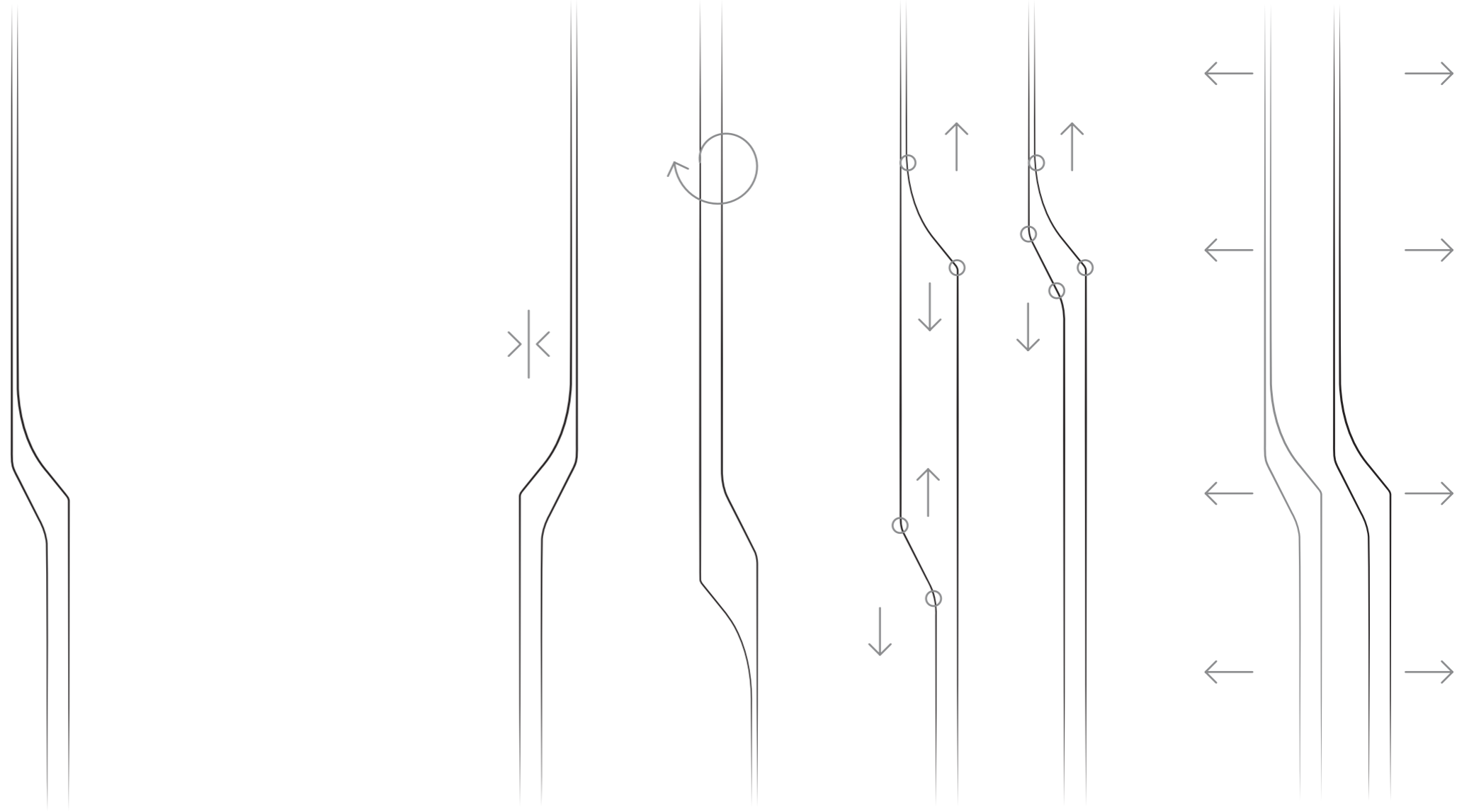

Mirroring

180° Rotation

Vertical translation

Horizontal translation
Multiple position possibility



Mirroring



180 Rotation



Vertical translation

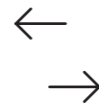

Horizontal translation

Notch Wall System

How to treat engravings on the Qbiss panels

62

500 mm from top

MATERIALS, COLORS AND FINISHING

PININFARINA/TRIMO_QBISS

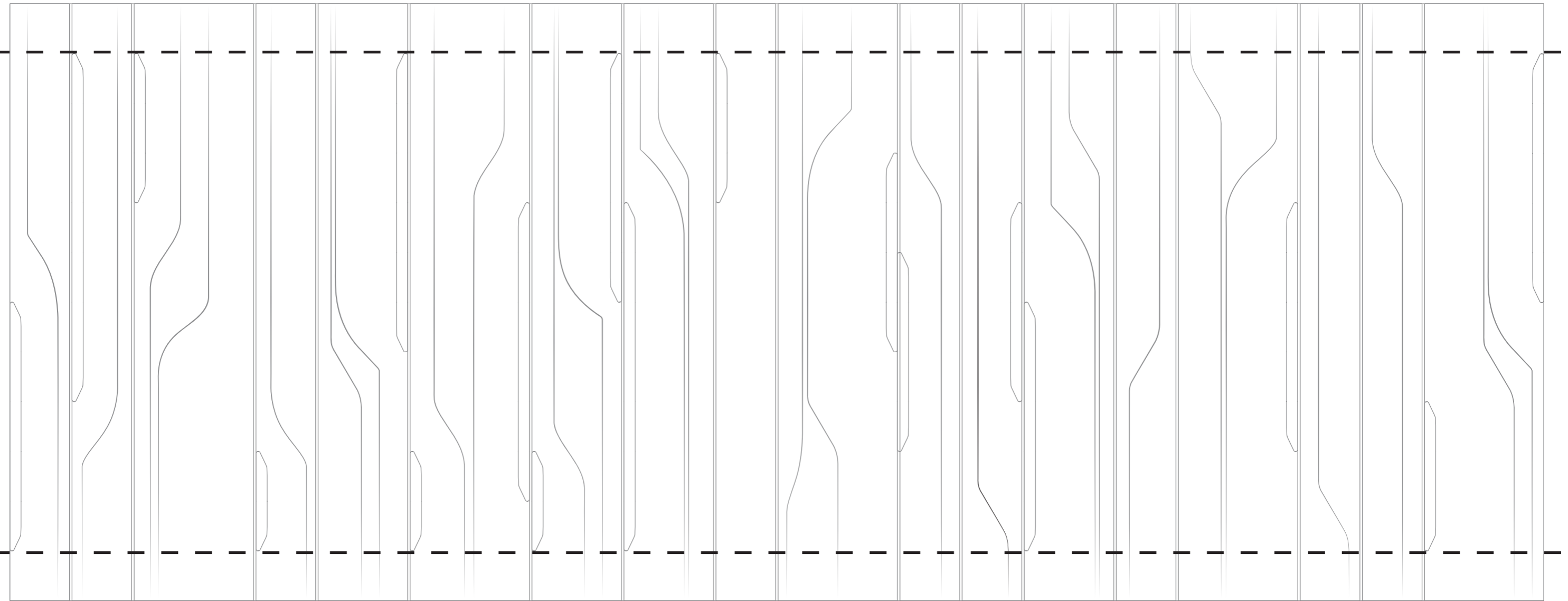

500 mm from bottom

Notes

CONTACTS

TRIMO D.O.O.

Prijateljjeva cesta 12,
8210 Trebnje, Slovenia

T **+386 (0)7 34 60 200**
F **+386 (0)7 34 60 127**

Email trimo@trimo-group.com

Web trimo-group.com

Pininfarina Architecture

Via Nazionale, 30
Cambiano (TO), Italy, 10020

T **+39 011 9438111**

Email architecture@pininfarina.com

Web pininfarina.com

Trimo Group holds full copyrights on the information and details provided in this document, therefore any unauthorised reproduction and distribution is strictly prohibited. Professional Care has been taken to ensure that the information/details are accurate, correct, complete and not misleading. However, Trimo, including its subsidiaries, does not accept responsibility or liability for errors or information, which is found to be misleading. Information/details in this document are for general purposes only. It is the user's responsibility to check compliance with local laws. Any deviations in details and project solutions are the user's responsibility. Under no circumstances, will we be liable for any loss or damage including without limitation, indirect or consequential

loss or damage, or any loss or damage whatsoever arising from lost profits as a result of or in connection with the use of this document. All information issued by Trimo Group is subject to continuous development and information/details contained in this document were current on the date of issue. It is the user's responsibility to obtain the most up-to-date information from Trimo when information/details are used for a project.

The latest version of the document is available at www.trimo-group.com. The latest version of the published document in English prevails over other translated documents. For information about the delivery of panels see Trimo's General conditions (<https://trimo-group.com/en/trimo/general-conditions-of-sales>).



